



Einhell

PUMPING MADE EASY.
WATER TECHNOLOGY FOR
HOUSE AND GARDEN.



[einhell.de](https://www.einhell.de)

>>>



WATER TECHNOLOGY

All you need to know about pumps	3
Pump Advisor	3
Drainage – Watering – Domestic Water Supply	4
The right Pump for the right Purpose	6
Pump Technology – Main Facts	8
Drainage – Submersible Pumps	10
Submersible Pumps at a Glance	10
Aqua Sensor Pumps	12
2-in-1 Multipurpose Pumps	14
For Environmental's Sake – pump right.	17
Submersible Pumps Dirty/Clear Water 'ECO'	18
Dirty Water Pumps	19
Cordless Clear Water Pumps	22
Rain Barrel Pump	24
Clear Water Pumps	25
Submersible Pressure Pumps	26
Deep Well Pumps	27

Watering – Surface Pumps	28
Surface Pumps at a Glance	28
Cordless Garden Pump AQUINNA	30
Surface Pumps 'Plus'	31
Garden Pumps 'Plus'	34
Garden Pumps	36
Domestic Water Supplies – Service water in the house and garden	38
Automatic Home and Garden Pumps 'Plus'	38
Automatic Home and Garden Pumps	40
Water Works 'Plus'	42
Water Works	44
Petrol Water Pumps	46
Accessories	48
Surface Pump Accessories	48
Which accessories go with which surface pump?	50
Service	52

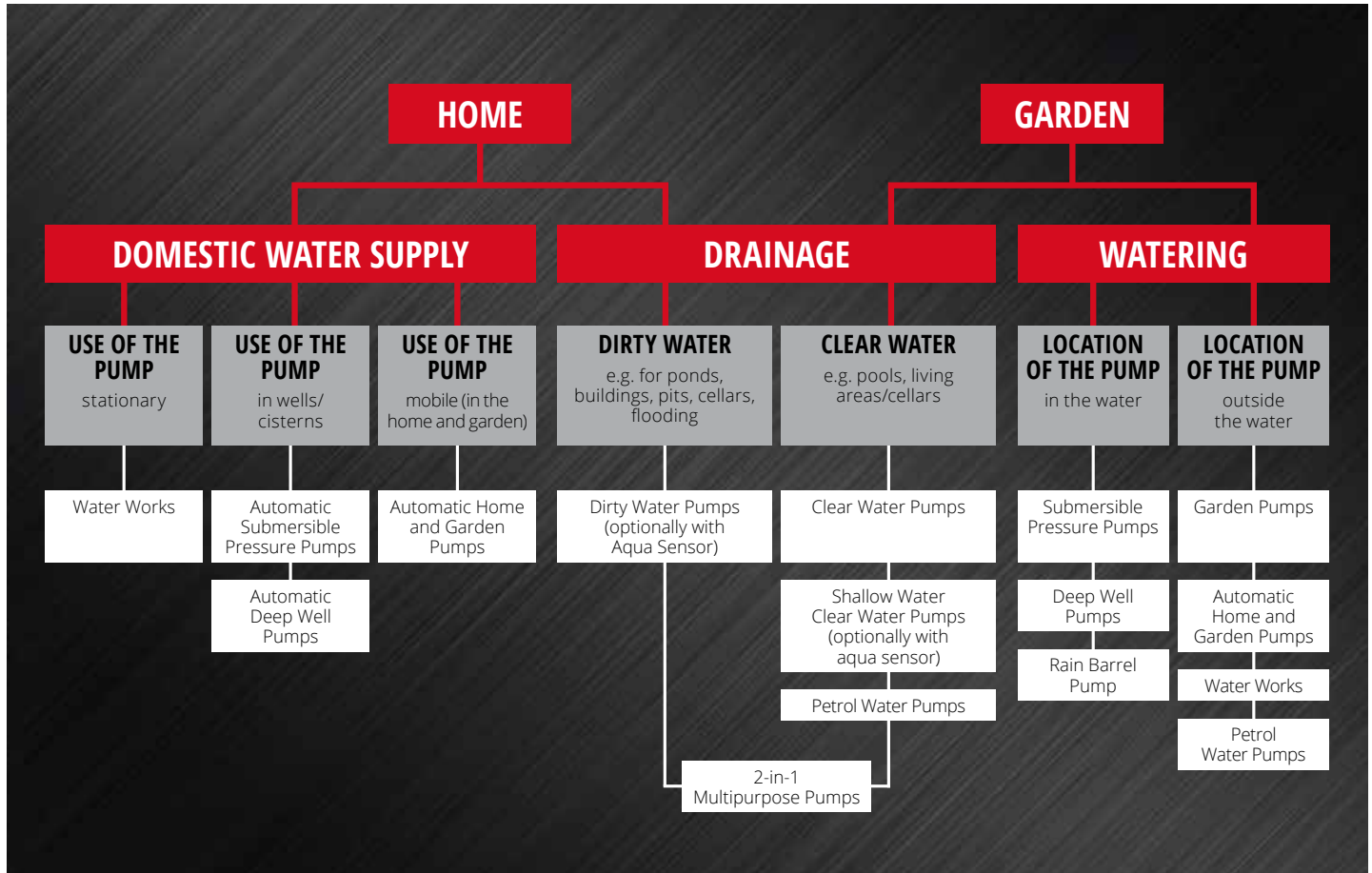



Powerful



Economical



Environmentally friendly



Versatile



DRAINAGE

Repumping/pumping out water – quicker and easier than ever. Pumping both clear water and dirty water with a high delivery rate is no problem with Einhell drainage pumps.

- Delivery of large quantities of water quickly
- Prevention of the worst water damage as far as possible by pumping out quickly
- High level of operational safety and reliability



WATERING

To avoid wasting precious drinking water on watering the garden, alternative sources of water such as rainwater or water from cisterns can be used instead.

- Uniform garden watering
- User-friendly and safe handling
- Conserves resources and saves drinking water



DOMESTIC WATER SUPPLY

Fully automatic and with constant pressure. With the domestic water pumps or automatic submersible pressure pumps from Einhell, you can put collected rainwater to use in the home, for example for toilet flushing, in your washing machine or for outdoor uses.

- Water supply for home and garden from alternative water reservoirs (cisterns, wells)
- User-friendly and safe handling
- Conserves resources and saves drinking water



DRAINAGE



WATERING



DOMESTIC WATER SUPPLY

THE RIGHT PUMP FOR THE RIGHT PURPOSE.

Whether in the home or in the garden – Einhell has the right pump for every application:

1 | DEEP WELL PUMP

for watering the garden

» Read more on p. 25

2 | RAIN BARREL PUMP

for easy drawing of water from rainwater reservoirs

» Read more on p. 22

NOW ALSO
AVAILABLE AS A
**CORD-
LESS**
VERSION
SEE P. 22

3 | MULTIPURPOSE PUMP / CLEAR WATER PUMP

for emptying pools

» Read more on pp. 14 - 15, p. 18 and p. 23

NOW ALSO
AVAILABLE AS A
**CORD-
LESS**
VERSION
SEE P. 23

4 | POWER X-CHANGE CORDLESS GARDEN PUMP

for cordless garden watering

» Read more on pp. 28 - 29

5 | SUBMERSIBLE PRESSURE PUMP

for watering the garden

» Read more on p. 24

6 | FOR WATERING THE GARDEN INDEPENDENTLY OF THE MAINS SUPPLY

for watering the garden independently of the mains supply

» Read more on p. 46

7 | MULTIPURPOSE PUMP / DIRTY WATER PUMP

for draining ponds

» Read more on pp. 14 - 15 and pp. 18 - 21

8 | GARDEN PUMP

for watering gardens from cisterns

» Read more on pp. 34 - 37

9 | AQUA SENSOR PUMP

for round-the-clock protection against flooding

» Read more on pp. 12 - 13

10 | AUTOMATIC HOME AND GARDEN PUMPS / WATER WORKS

for automatic domestic water supplies with service water

» Read more on pp. 38 - 45





1

SUCTION HEIGHT

The suction height defines the height difference that can be overcome between the component at the heart of the pump, the paddle wheel, and the surface of the water. The suction capacity is based on the atmospheric air pressure under real conditions, as a result of which pumps generally face a physical limit of around 10 metres.

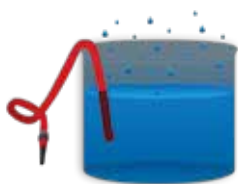

2

SERVICE WATER

Service water is water that is pumped by means of a pump from a well, shaft or cistern. It is not potable and must not be used for drinking water or for the preparation of food. In private households, service water can be used in separate outlets away from the drinking water supply as a supply for toilet flushing systems or washing machines, or as cleaning water.



3

DELIVERY PRESSURE

The delivery pressure describes the pressure with which the pump acts on the fluid being pumped. The higher the force of the pump used for pumping, the higher the pressure. Pressure is generally measured in bar, occasionally also in pascal. The delivery pressure also indicates the delivery head – e.g. a delivery head of 35 m corresponds to a delivery pressure of 3.5 bar.



4

DELIVERY HEAD

The delivery head describes the difference in height between the pump and the outlet of the water from the connected hose/sprinkler (caution: in the case of pumps that are submerged in water, the position of the pump is not used, but instead the height of the water surface).



5

DELIVERY RATE

The delivery rate, also referred to as the pumping capacity or suction capacity, describes the pumping capacity of a pump and is normally stated in 'liters per hour'. The delivery rate can also be described as a volumetric flow or flow rate, where the units 'cubic meters per second' are used. The delivery rate depends on the delivery height – the higher the water is pumped, the lower the delivery rate will be.



6

CLEAR WATER

Clear water is slightly contaminated waste water with no particulate content. This includes waste water from personal hygiene, but not kitchen waste water, which is excluded because of the high levels of oils and bacteria from food waste. Clear water is not potable and must not be used for drinking water or for the preparation of food.

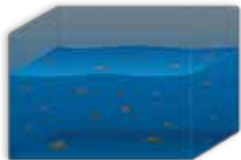

7

DIRTY WATER

Dirty water is the combined total of all waste water in the household and in commercial or agricultural operations, and it is heavily contaminated with bacteria. Dirty water must be purified via mechanical, chemical or biological means before it can be fed back into the water circuit.

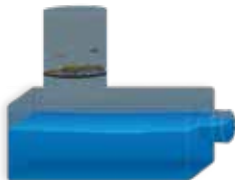

8

PRE-FILTER

Pre-filters prevent the ingress of contamination into the pump. Their use is always recommended if the pump is expected to pump water that may be contaminated and may contain sand or dirt particles.

SUBMERSIBLE PUMPS AT A GLANCE.

Whether for pumping out a flooded cellar or a construction pit, or for emptying pools or ponds – submersible pumps are the **perfect aid**. The main task of a submersible pump is to pump as much water as possible within the shortest possible time. The parameter that describes this ability is known as the delivery rate and is measured in liters/h.

Submersible pumps can be divided into two categories: Depending on the area of application and how clean or dirty the water is that is to be pumped, you can choose either a **clear water pump** or a **dirty water pump**. But our range of submersible pumps also includes **multitalents** such as the 2-in-1 combination pumps for clear water and dirty water.

For more challenging tasks, such as pumping water from greater depths or under particularly high pressure, our deep well and submersible pressure pumps do a really fine job.



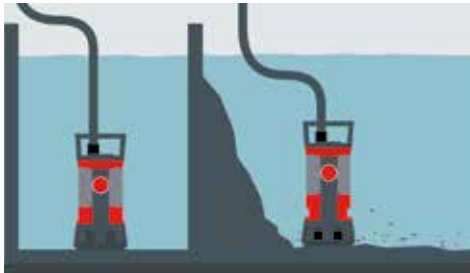

1

AQUA SENSOR PUMPS

Pump clear water or dirty water at any time thanks to the automatic sensor start function.



2

DIRTY WATER PUMPS

Quickly pump out dirty water from ponds, construction pits or cellars.

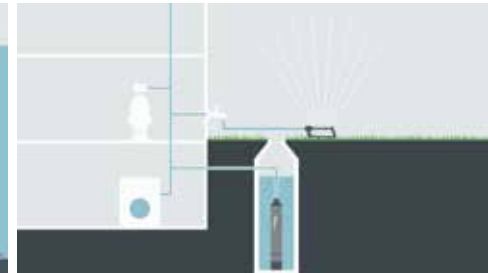

3

DEEP WELL PUMPS

For pumping water from particularly large depths for house and garden.

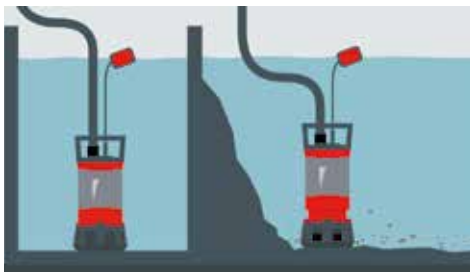

4

2-IN-1 MULTIPURPOSE PUMPS

Pump clean water and dirty water with the aid of the suction level adjustment.



NOW ALSO
AVAILABLE AS A
**CORD-
LESS
VERSION**
SEE P. 23

5

CLEAR WATER PUMPS

Quickly pump out clean water from pools, living areas or cellars.

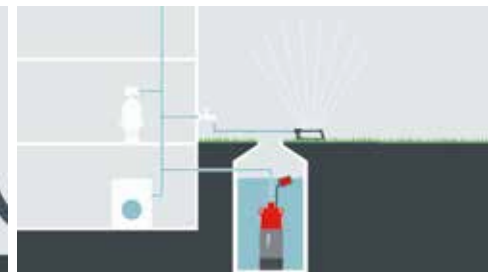

6

SUBMERSIBLE PRESSURE PUMPS

For pumping water to particularly great heights or under very high pressure for house and garden.

24/7 PROTECTION FROM FLOODS.

Thanks to our **Aqua Sensor Technology**, the pumps operate with **patented** sensor adjustment at **three automatic starting heights** or can be used in continuous operation. Thanks to the integrated aqua sensor, the pumps offer a slimline design and can be used in narrow shafts.

Increased safety for your home so you can enjoy your holiday without worries: The aqua sensor continuously monitors its environment and, depending on the model, sucks up the water until the surroundings can be wiped dry. This puts an end to unplanned and expensive surprises and provides you with immediate, **round-the-clock protection** – 24 hours a day, even when you are away.

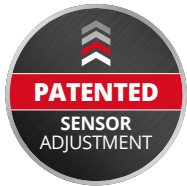

Clearly arranged adjustment of the three automatic sensor starting heights or the permanent mode.

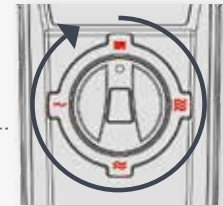
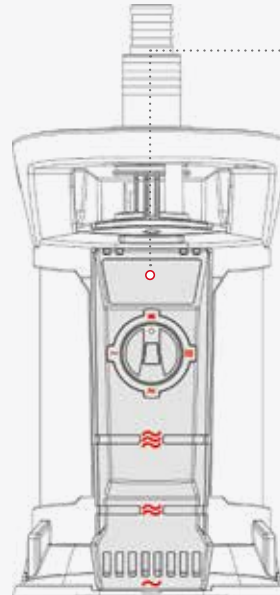

Permanent mode (ON/OFF) without using the sensor – pump start		
	5 mm	50 mm
Automatic sensor start at	103 mm	188 mm
Automatic sensor start at	56 mm	135 mm
Automatic sensor start at	5 mm	70 mm

AQUA SENSOR DIRTY WATER PUMPS



	GE-DP 7935 N-A ECO EXPERT	GE-DP 6935 A ECO EXPERT
Mains voltage	230 V ~ 50 Hz	230 V ~ 50 Hz
Rated input	790 W	690 W
Max. delivery capacity / height	19000 l/h / 9 m	17500 l/h / 9 m
Max. immersion depth	7 m	7 m
Max. size of foreign particle	35 mm	35 mm
Pump start during continuous operation	50 mm	50 mm
Sensor starting heights	70 mm / 135 mm / 188 mm	70 mm / 135 mm / 188 mm
Suction down to	40 mm	40 mm
Hose connection	47.8 mm (1½") ET	47.8 mm (1½") ET
Power cord	10 m	10 m
Product weight	6.2 kg	5.7 kg
Aqua Sensor Technology	•	•
Permanent mode without sensor start	•	•
Non-return valve	•	•
High-quality mechanical seal	•	•
Integrated cable rewind	•	•
Carry handle	•	•
Lifting eye	•	•
ECO Power	•	•
Universal hose adapter	•	•
Article number	41.714.60	41.714.50

AQUA SENSOR CLEAR WATER PUMPS



	GE-SP 4390 N-A LL ECO EXPERT
Mains voltage	230 V ~ 50 Hz
Rated input	430 W
Max. delivery capacity / height	9000 l/h / 8 m
Max. immersion depth	7 m
Max. size of foreign particle	1 mm
Pump start during continuous operation	5 mm
Sensor starting heights	5 mm / 56 mm / 103 mm
Works in shallow clean water as low as	1 mm
Hose connection	47.8 mm (1½") ET
Power cord	10 m
Product weight	4.9 kg
Aqua Sensor Technology	•
Permanent mode without sensor start	•
Non-return valve	•
High-quality mechanical seal	•
Integrated cable rewind	–
Carry handle	•
Lifting eye	•
ECO Power	•
Universal hose adapter	•
Article number	41.714.40

OUR ALL-ROUNDERS.

The **2-in-1 Multipurpose Pumps** from Einhell are robust, powerful and reliable aids for pumping out ponds, construction pits and flooded cellars quickly and energy-efficiently, as well as for many other drainage tasks.

Two genuine all-rounders: With the patented suction level adjustment, a simple rotary motion on the foot of the pump allows the unit to be quickly adapted to the required function (clean water mode or dirty water mode) – providing users with a combination pump for two different tasks: for shallow-water applications down to a residual water layer depth of 1 mm in clean water mode (meaning, for example, that a cellar can then simply be wiped dry) or for sucking up dirty water containing dirt particles with a size of up to 30 mm.



2-IN-1 MULTIPURPOSE PUMPS



	GE-DP 7330 LL ECO EXPERT	GE-DP 5220 LL ECO EXPERT
Mains voltage	230 V ~ 50 Hz	230 V ~ 50 Hz
Rated input	730 W	520 W
Max. delivery capacity / height	16500 l/h / 8.5 m	13500 l/h / 7.5 m
Max. immersion depth	7 m	7 m
Max. size of foreign particle	30 mm	20 mm
Works in shallow clean water as low as	1 mm	1 mm
Starting of pump from water level of	10 mm	10 mm
Hose connection	47.8 mm (1½") ET	47.8 mm (1½") ET
Power cord	10 m	10 m
Product weight	6.2 kg	5.4 kg
Patented suction level control	•	•
High-quality mechanical seal	•	•
Float switch (automatic + manual mode)	•	•
Integrated cable rewind	•	•
ECO Power	•	•
Carry handle with integrated lifting eye	•	•
Universal hose adapter	•	•
Article number	41.707.90	41.707.80



FOR ENVIRONMENTAL'S SAKE – PUMP RIGHT.

Water is one of the most valuable resources we have. It is high time we optimise our consumption. Especially in summer. The large quantities of water we need for our garden quite often come straight from the water mains. It is more environmentally friendly to use natural rain water or ground water, either from cisterns, wells or rainwater tanks.

Einhell water pumps help you use these natural sources in an efficient and sustainable manner. Whether it is a garden pump to water your plants or a domestic water supply system for the flushing toilets etc.: The Einhell pump advisor will find the right pump that meets your requirements.

WHERE TECHNICAL EXPERTISE AND ENHANCED ENVIRONMENTAL PROTECTION MEET

Each of us is responsible for the environment in which we live. Even as individuals, we have an important role to play. Our contribution: expertise and technology for efficient resource utilization. ECO Power stands for the use of efficient technology.

For example, our ECO Pumps feature the latest advances in technology which appreciably improve the energy-to-performance output ratio.



PERFECT FLOW GEOMETRY

An optimised hydrodynamic flow duct reduces the flow resistance and 4100 l/h enables powerful, obstruction-free pumping of the water.



OPTIMISED IMPELLER

The optimised impeller with modified vane geometry ensures perfect flow characteristics. Powerful, fault-free operation, maximum flow rate and minimal electricity consumption are thus possible.



HIGH-GRADE MECHANICAL SEAL

We have designed high-grade mechanical seals into our ECO Power dirty water pumps to reduce friction and wear even in demanding conditions. The pumps last longer, reducing both resource consumption and the impact on the environment.

SUBMERSIBLE PUMPS DIRTY/CLEAR WATER 'ECO'



	GE-DP 7935 N ECO EXPERT	GE-DP 6935 ECO EXPERT	GE-DP 3925 ECO EXPERT	GE-SP 4390 LL ECO EXPERT
Suitable for	Dirty water	Dirty water	Dirty water	Clear water
Mains voltage	230 V ~ 50 Hz	230 V ~ 50 Hz	230 V ~ 50 Hz	230 V ~ 50 Hz
Rated input	790 W	690 W	390 W	430 W
Max. delivery capacity / height	20000 l/h / 9 m	17500 l/h / 9 m	10000 l/h / 6 m	9000 l/h / 8 m
Max. immersion depth	7 m	7 m	7 m	7 m
Min. water level for pump start	50 mm	50 mm	50 mm	5 mm
Works in shallow clean water as low as	-	-	-	1 mm
Max. size of foreign particle	35 mm	35 mm	25 mm	1 mm
Hose connection	47.8 mm (1½") ET	47.8 mm (1½") ET	47.8 mm (1½") ET	47.8 mm (1½") ET
Power cord	10 m	10 m	10 m	10 m
Product weight	7.3 kg	5.5 kg	4.5 kg	4.5 kg
Integrated lifting eye	•	•	•	•
High-quality mechanical seal	•	•	•	•
Float switch (automatic + manual mode)	•	•	•	•
Integrated cable rewind	•	•	•	-
ECO Power	•	•	•	•
Carry handle	•	•	•	•
Non-return valve	-	-	-	•
Universal hose adapter	•	•	•	•
Article number	41.707.00	41.707.20	41.707.10	41.707.15

OUR HEAVYWEIGHTS.

Thanks to the extremely durable pump housing made of corrosion-resistant stainless steel and cast metal (depending on the model), the pumps can reliably withstand even the harshest levels of use. In addition, sturdy cast metal parts are provided on some of our models to provide them with a particularly secure and stable footing, particularly in very dirty water.



DIRTY WATER PUMPS



	GC-DP 1340 G CLASSIC	GC-DP 5010 G CLASSIC	GC-DP 9035 N CLASSIC
Mains voltage	230 V ~ 50 Hz	220 - 240 V ~ 50 Hz	220 - 240 V ~ 50 Hz
Rated input	1300 W	500 W	900 W
Max. delivery capacity / height	23000 l/h / 10 m	12000 l/h / 8 m	18000 l/h / 9 m
Max. immersion depth	5 m	5 m	5 m
Max. size of foreign particle	40 mm	10 mm	35 mm
Hose connection	59.6 mm (2") IT	42 mm (1¼") IT	47.8 mm (1½") IT
Power cord	10 m	10 m	10 m
Product weight	22.0 kg	10.6 kg	5.95 kg
Integrated lifting eye	-	-	-
High-quality mechanical seal	•	•	•
Floating switch	Automatic mode	Automatic mode	Automatic + manual mode
Integrated cable rewind	-	-	-
ECO Power	-	-	-
Carry handle	•	•	•
Universal hose adapter	•	•	•
Lowering rope	• (6 m)	-	-
Article number	41.707.42	41.714.21	41.707.78

OUR COMPACT HELPERS.

Robust, powerful and extremely reliable helpers for pumping out construction pits, wells and other very dirty bodies of water.



DIRTY WATER PUMPS



AUTUMN
2021



	GC-DP 9040 N CLASSIC NEW	GC-DP 7835 CLASSIC
Mains voltage	230 V ~ 50 Hz	230 V ~ 50 Hz
Rated input	900 W	780 W
Max. delivery capacity / height	22000 l/h / 9 m	15700 l/h / 8 m
Max. immersion depth	7 m	7 m
Max. size of foreign particle	40 mm	35 mm
Hose connection	50 mm (2") IT	47.8 mm (1½") IT
Power cord	10 m	10 m
Product weight	7.5 kg	5.2 kg
Integrated lifting eye	-	-
High-quality mechanical seal	•	•
Float switch (automatic + manual mode)	•	•
Integrated cable rewind	•	•
ECO Power	-	-
Carry handle	•	•
Universal hose adapter	•	•
Lowering rope	-	-
Article number	41.815.10	41.706.82

DIRTY WATER PUMPS



AUTUMN 2021



	GC-DP 6315 N CLASSIC	GC-DP 5225 N CLASSIC	GC-DP 3730 CLASSIC	GC-DP 3325 CLASSIC NEW
Mains voltage	230 V ~ 50 Hz	230 V ~ 50 Hz	230 V ~ 50 Hz	230 V ~ 50 Hz
Rated input	630 W	520 W	370 W	330 W
Max. delivery capacity / height	17000 l/h / 8 m	10000 l/h / 7 m	9000 l/h / 5 m	9500 l/h / 6 m
Max. immersion depth	5 m	5 m	5 m	5 m
Max. size of foreign particle	15 mm	25 mm	30 mm	25 mm
Hose connection	47.8 mm (1½") IT	47.8 mm (1½") IT	47.8 mm (1½") IT	47.8 mm (1½") IT
Power cord	10 m	10 m	10 m	10 m
Product weight	4.7 kg	4.1 kg	4.3 kg	3.6 kg
Integrated lifting eye	-	-	-	-
High-quality mechanical seal	•	•	•	•
Float switch (automatic + manual mode)	•	•	•	•
Integrated cable rewind	•	•	•	-
ECO Power	-	-	-	-
Carry handle	•	•	•	• (folding)
Universal hose adapter	•	•	•	•
Lowering rope	-	-	-	-
Article number	41.704.91	41.704.81	41.704.71	41.815.30

CORDLESS FREEDOM. WITH CORDLESS PUMPS

These cordless clear water pumps are high-performance members of the Power X-Change family. They convey water independently of the mains supply, are flexible in use and powerful in operation.

Thanks to its high delivery pressure, the 2-in-1 pump GE-PP 18 RB Li can be used as a submersible pressure pump, e.g. in a cistern, but also as a rainwater barrel pump when combined with the adjustable connecting pipe.

With its lower pressure but higher delivery rate the cordless clear water pump GE-SP 18 Li is ideal for pumping out and repumping water wherever it needs to be conveyed independently of a mains power supply.



CORDLESS CLEAR WATER PUMPS



	GE-PP 18 RB Li - Solo EXPERT PLUS NEW
PXC battery voltage / capacity	18 V / -
Max. delivery capacity / height	3000 l/h / 20 m
Max. immersion depth	4 m
Hose connection	33.3 mm (1") ET
Power cord	5 m
Product weight with / without accessories	2.5 / 3.1 kg
Mobile battery box	•
Integrated cable rewind	•
Integrated wall mount	•
Suspension device made from stainless steel	•
Telescopic extension tube	•
Flexible gooseneck	•
Number of batteries / number of chargers	0 / 0
Article number	41.704.29



	GE-SP 18 Li - Solo EXPERT PLUS NEW
PXC battery voltage / capacity	18 V / -
Max. delivery capacity / height	5000 l/h / 8 m
Max. immersion depth	4 m
Hose connection	33.3 mm (1") ET
Power cord	5 m
Product weight with / without accessories	2.6 / 2.7 kg
Mobile battery box	•
Integrated cable rewind	•
Integrated wall mount	•
Suspension device made from stainless steel	•
Telescopic extension tube	-
Flexible gooseneck	-
Number of batteries / number of chargers	0 / 0
Article number	41.815.00



THE PRACTICAL RAIN BARREL PUMP.

High-quality, reliable and efficient helper which was designed specially for drawing water from rain barrels and cisterns. An infinitely variable float switch can be used to set this robust pump to continuous operation or to a specific ON and OFF switching level. The pump has a flexible swan-neck with stopcock for individual positioning of the garden hose, as well as a rain barrel bracket for securing the pump to the barrel itself.



RAIN BARREL PUMP



	GE-SP 3546 RB EXPERT
Mains voltage	230 V ~ 50 Hz
Rated input	350 W
Max. delivery capacity / height	4600 l/h / 11 m
Max. immersion depth	7 m
Max. size of foreign particle	2.5 mm
Hose connection	26.4 mm (3/4") ET
Power cord	10 m
Suction down to	-
Product weight	5.0 kg
High-quality mechanical seal	-
Floating switch (infinitely variable)	•
Integrated cable rewind	•
Carry handle	•
Flexible gooseneck	•
Storage compartment for extensions	•
Universal hose adapter	-
Article number	41.704.38

FLEXIBILITY FOR CLEAR WATER APPLICATIONS.

Ideal for drainage, removal and transportation of clean and slightly soiled water.

CLEAR WATER PUMPS



AUTUMN
2021



	GE-SP 750 LL EXPERT	GC-SP 5511 IF CLASSIC	GC-SP 3580 LL CLASSIC	GC-SP 2768 CLASSIC	GC-SP 2275 CLASSIC NEW
Mains voltage	230 V ~ 50 Hz	230 V ~ 50 Hz	230 V ~ 50 Hz	230 V ~ 50 Hz	230 V ~ 50 Hz
Rated input	750 W	550 W	350 W	270 W	220 W
Max. delivery capacity / height	15000 l/h / 10 m	11000 l/h / 8.5 m	8000 l/h / 7.5 m	6800 l/h / 5.5 m	7500 l/h / 6 m
Max. immersion depth	5 m	7 m	7 m	5 m	5 m
Hose connection	42 mm (1¼") ET	47.8 mm (1½") IT	47.8 mm (1½") IT	47.8 mm (1½") IT	47.8 mm (1½") IT
Power cord	10 m	10 m	10 m	10 m	10 m
Min. water level for pump start	50 mm	60 mm	8 mm	-	-
Suction down to	2 mm	5 mm	1 mm	8 mm	8 mm
Product weight	6.2 kg	4.4 kg	3.1 kg	3.9 kg	3.4 kg
High-quality mechanical seal	•	-	•	•	•
Float switch (automatic + manual mode)	• (integrated)	• (integrated)	•	•	•
Integrated cable rewind	•	-	•	•	-
Carry handle	•	•	•	•	• (folding)
Universal hose adapter	•	•	•	•	•
Article number	41.706.66	41.704.63	41.704.45	41.704.42	41.815.20

WATER POWER FOR HOUSE AND GARDEN.

If you need to pump water to particularly great heights or under very high pressure, then our submersible pressure pumps offer just the support you need.

The automatic function of the GE-PP 5555 RB-A represents an ideal and convenient solution, be it for watering gardens from a rain barrel via a practical extension pipe or for maintaining domestic water supplies.



SUBMERSIBLE PRESSURE PUMPS



	GE-PP 1100 N-A EXPERT	GC-PP 900 N CLASSIC	GE-PP 5555 RB-A EXPERT NEW
Mains voltage	220 - 240 V ~ 50 Hz	230 V ~ 50 Hz	230 - 240 V ~ 50 Hz
Rated input	1100 W	900 W	550 W
Max. delivery capacity / height	6000 l/h / 45 m	6000 l/h / 32 m	5500 l/h / 20 m
Max. immersion depth	12 m	7 m	7 m
Max. size of foreign particle	-	2.5 mm	-
Hose connection	33.3 mm (1") IT	33.3 mm (1") IT	33.3 mm (G1) ET
Power cord	15 m	10 m	10 m
Product weight	8.7 kg	8.9 kg	5.0 kg
Automatic mode	•	-	•
Float switch (automatic + manual mode)	-	•	-
Dry operation protection	•	-	•
Multi-stage pump impeller	• (4 pcs)	• (3 pcs)	• (2 pcs)
High-quality mechanical seal	•	•	•
Overload cut-out	•	•	•
Integrated non-return valve	•	-	•
Stainless dirt screen	•	-	-
High-quality INOX high-grade steel pump housing	•	•	-
Integrated cable rewind	-	-	•
Carry handle	•	-	•
Telescopic extension tube	-	-	•
Flexible gooseneck	-	-	•
Article number	41.714.30	41.709.64	41.704.25

WATER SUPPLY FROM DEEP RESERVOIRS.

Deep Well Pumps are extremely powerful and reliable devices for pumping water from deep reservoirs, wells or constricted pipes. They provide high pressure delivery for e.g. watering the garden and thanks to the automatic function, are also suitable for domestic water supplies. The sturdy pump housings are made of corrosion-resistant stainless steel.



DEEP WELL PUMPS



STAINLESS STEEL



	GE-DW 1100 N-A EXPERT	GC-DW 1300 N CLASSIC	GC-DW 1000 N CLASSIC
Mains voltage	220 - 240 V ~ 50 Hz	230 V ~ 50 Hz	220 - 240 V ~ 50 Hz
Rated input	1100 W	1300 W	1000 W
Max. delivery capacity / height	6000 l/h / 55 m	5000 l/h / 65 m	6500 l/h / 45 m
Max. immersion depth	19 m	20 m	19 m
Max. size of foreign particle	-	-	-
Hose connection	33.3 mm (1") IT	47.8 mm (1½") IT	42 mm (1¼") IT
Power cord	22 m	2 m / 23 m	22 m
Pump diameter	99 mm	102 mm	98 mm
Product weight	9.81 kg	15.5 kg	7.7 kg
Automatic mode	•	-	-
Dry operation protection	•	-	-
Multi-stage pump impeller	• (8 pcs)	• (10 pcs)	• (6 pcs)
High-quality mechanical seal	•	•	•
Overload cut-out	•	•	•
Integrated non-return valve	•	•	•
Stainless dirt screen	•	•	•
High-quality INOX high-grade steel pump housing	•	•	•
External switchbox	-	•	-
Lowering rope	• (22 m)	• (20 m)	• (22 m)
Article number	41.709.35	41.709.44	41.709.55



SURFACE PUMPS AT A GLANCE.

No matter whether for watering tasks in the garden or for Domestic Water Supplies – Einhell surface pumps like garden pumps, automatic home and garden pumps, domestic water works or petrol water pumps are perfectly equipped for these challenges. Thanks to the high delivery pressure, high delivery heads or long delivery distances can be easily overcome.

With garden pumps or automatic home and garden pumps, groundwater can be pumped efficiently and safely for the environment from wells or cisterns and easily used to water the garden.

Fully automatic and with constant pressure with Einhell domestic water works and automatic home and garden pumps you can use collected service water in the home, for example to flush the toilet or in your washing machine.

And if no power supply is available, the range of cordless or petrol water pumps from Einhell is on hand to deliver pumping capability in any location.



1

GARDEN PUMPS

For watering the garden.

NOW ALSO
AVAILABLE AS A
**CORD-
LESS
VERSION**
SEE P. 30



2

AUTOMATIC HOME AND GARDEN PUMPS

For automatic garden watering and domestic water supplies.



3

WATER WORKS

For automatic domestic water supplies or garden watering.



4

PETROL WATER PUMPS

For watering and drainage tasks – independently of the mains power supply.



POWER X-CHANGE GARDEN PUMP

POWER X-CHANGE

The Einhell AQUINNA Power X-Change Garden Pump leaves nothing to be desired when it comes to cordless freedom. Whether for working in your allotment, on a camping trip or if the nearest socket outlet in the garden is simply too far away – no problem for the compact and user-friendly AQUINNA. It can be quickly transported from A to B and has 36 V (2 x 18 V) of power to deliver up to 3,000 liters per hour at up to 2.8 bar. Where less pressure might occasionally be required, a 2-level switch enables it to be easily switched to ECO mode, doubling the running time at the same time.



CORDLESS GARDEN PUMP

AQUINNA

36 V
POWER
2 x 18 V



	AQUINNA 36/30 EXPERT PLUS
PXC battery voltage / capacity	2x 18 V / –
Max. delivery capacity / height	3000 l/h / 26 m
Max. suction height	8 m
Suction connection	42 mm (1½") ET
Pressure connection	33.3 mm (1") IT
Product weight	3.3 kg
Water filler screw	•
Water drain screw	•
2-step ECO switch	•
Carry handle	•
Incl. adapter 33.3 mm (1") ET	•
Article number	41.804.00

SURFACE PUMPS 'PLUS'

EASY PUMPING WITH THE NEW SURFACE PUMP GENERATION FROM EINHELL.

Fast and easy installation as well as quick error detection thanks to **status indicators**.



EXPERT Version

WATER FILLING INDICATOR

Before starting-up the pump for the first time it needs to be filled with water to secure a flawless intake procedure. Thanks to the sight glass the customer can see at first sight if there is already enough water filled into the pump.



CLASSIC Version



PRE-FILTER

Integrated filter incl. non-return valve – easy to take out for cleaning or replacement.



SUCTION INDICATOR

A pressure gauge in the cover of the water filling opening continuously shows the current suction pressure and the suction height.

BIG WATER FILLER SCREW

Big water filler opening through which it is very easy to fill water into the pump.

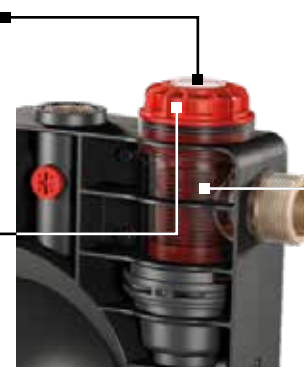

DIRT INDICATOR

Thanks to the transparent housing surrounding the coarse filter, it is easy to see whether the filter is dirty and may need cleaning.

SURFACE PUMPS 'PLUS'

Long life, low maintenance and exceptional **protection** thanks to special **safety mechanisms**.

SCALDING PROTECTION

As part of the dry-run safeguard system, the scalding protection function prevents the water remaining in the pump's body from getting hot. If the pump outlet (on the delivery side) should close or become partly blocked for whatever reason and the pump continue to work, the water would gradually become hotter and hotter. The scalding protection function prevents this and switches off the pump in good time.

FROST PROTECTION – WATER DRAIN SCREW

Often consumers forget to empty the pump before winter and the water left inside the pump freezes and destroys the pump. To prevent water from freezing inside the pump there is a convenient water drain screw for letting out the water in very little time.

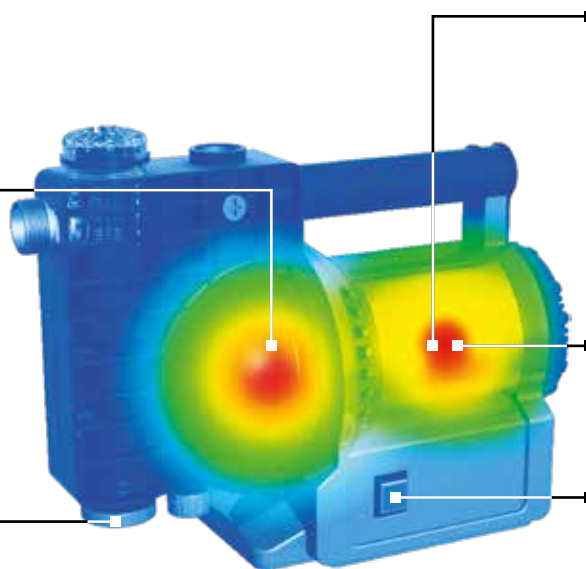

DRY RUNNING PROTECTION

If the pump is no longer able to draw in any water (e.g. the water source is empty), the dry running protection function will recognize this and will stop the pump after approx. 30 seconds in idle mode. If there is still no water being drawn in when it tries to restart the pump, it will stop again within another 30 seconds and shut off the pump. This prevents overheating of not only the pump but also the motor.

THERMO PROTECTION

To prevent severe damage, the integrated thermo switch cuts off the pump when the motor overheats.

WATER FLOW RECOGNITION SENSOR

A sensor indicates (by LEDs or an LCD display, depending on the model) if there is proper water flow:



- Red: Failure – no water in the pump
- Yellow: Flow detection
- Green: Pump runs normal

SURFACE PUMPS 'PLUS'

FEATURE SEGMENTATION		
	EXPERT	CLASSIC
Garden Pumps	GE-GP 1145 ECO GE-GP 1246 N FS	GC-GP 6040 ECO GC-GP 8042 ECO GC-GP 1045 GC-GP 1250 N
Automatic Home and Garden Pumps	GE-AW 1042 FS GE-AW 1246 N FS	–
Water Works	GE-WW 1145 ECO GE-WW 1246 N FS	GC-WW 8042 ECO GC-WW 1045 N
STATUS INDICATORS		
Water Filling Indicator*	●	●
Suction Indicator*	●	–
Dirt Indicator (Pre-filter with non-return valve)	●	–
SAFETY + PROTECTION		
Flow Sensor	● (except GE-GP/WW 1145 ECO)	–
Dry Running Protection	● (except GE-GP/WW 1145 ECO)	–
Scalding Protection	● (except GE-GP/WW 1145 ECO)	–
Thermo Protection	●	●
Frost Protection	●	●

* Patent pending

GARDEN PUMPS 'PLUS'

Einhell Garden Pumps Plus have innovative features to make them even more user-friendly than previous garden pumps.

Starting up and troubleshooting are even easier than ever before thanks to innovative status indicators such as suction, dirt and water filling indicators. For a long service life, low maintenance and exceptional protection, some models have special safety mechanisms such as the flow sensor, dry running protection, scalding protection and frost protection. But every model has a thermo switch for protection against damage caused by overheating of the motor.

GARDEN PUMPS 'PLUS'



	GE-GP 1246 N FS EXPERT	GE-GP 1145 ECO EXPERT
Mains voltage	220 - 240 V ~ 50 Hz	220 - 240 V ~ 50 Hz
Rated input	1200 W	1100 W
Max. delivery capacity / height	4600 l/h / 50 m	4500 l/h / 48 m
Max. suction height	8 m	8 m
Suction connection	42 mm (1¼") ET	42 mm (1¼") ET
Pressure connection	33.3 mm (1") IT	33.3 mm (1") IT
Additional pressure side connection	33.3 mm (1") IT	33.3 mm (1") IT
Power cord	1.5 m	1.5 m
Product weight	14.0 kg	14.0 kg
Water filler screw	•	•
Water filling / dirt / suction indicators	• / • / •	• / • / •
Integrated pre-filter with non-return valve	•	•
Carry handle	Comfort	Comfort
Frost protection due to a water drain screw	•	•
Thermo protection	•	•
Water flow recognition sensor / dry running protection / scalding protection	• / • / •	- / - / -
ECO Power	-	•
Incl. adapter 33.3 mm (1") ET	•	•
Article number	41.803.60	41.803.70

GARDEN PUMPS 'PLUS'



	GC-GP 1250 N CLASSIC	GC-GP 1045 CLASSIC	GC-GP 8042 ECO CLASSIC	GC-GP 6040 ECO CLASSIC
Mains voltage	220 - 240 V ~ 50 Hz	220 - 240 V ~ 50 Hz	220 - 240 V ~ 50 Hz	220 - 240 V ~ 50 Hz
Rated input	1200 W	1050 W	800 W	600 W
Max. delivery capacity / height	5000 l/h / 50 m	4500 l/h / 48 m	4200 l/h / 43 m	4000 l/h / 36 m
Max. suction height	8 m	8 m	8 m	8 m
Suction connection	42 mm (1¼") ET	42 mm (1¼") ET	42 mm (1¼") ET	42 mm (1¼") ET
Pressure connection	33.3 mm (1") IT	33.3 mm (1") IT	33.3 mm (1") IT	33.3 mm (1") IT
Additional pressure side connection	-	-	-	-
Power cord	1.5 m	1.5 m	1.5 m	1.5 m
Product weight	9.7 kg	9.5 kg	8.2 kg	6.1 kg
Water filler screw	•	•	•	•
Water filling / dirt / suction indicators	• / - / -	• / - / -	• / - / -	• / - / -
Integrated pre-filter with non-return valve	-	-	-	-
Carry handle	Comfort	Comfort	Foldable	Foldable
Frost protection due to a water drain screw	•	•	•	•
Thermo protection	•	•	•	•
ECO Power	-	-	•	•
Incl. adapter 33.3 mm (1") ET	•	•	•	•
Article number	41.803.50	41.803.40	41.803.30	41.803.20

ALLROUNDERS FOR THE GARDEN.

Einhell Garden Pumps are useful aids for watering the garden. Water from ponds, water butts or wells are ideally suited to watering lawns or plants, avoiding the use of valuable drinking water resources in the process. Just like all of our other surface pumps, the garden pumps are placed outside the water, which they suck in via a suction hose and pump through a pressure hose/delivery hose to the consumers.

GARDEN PUMPS



	GC-GP 1250 N CLASSIC	GC-GP 1046 N CLASSIC
Mains voltage	220 - 240 V ~ 50 Hz	220 - 240 V ~ 50 Hz
Rated input	1200 W	1050 W
Max. delivery capacity / height	5000 l/h / 50 m	4600 l/h / 48 m
Max. suction height	8 m	8 m
Suction connection	42 mm (1½") ET	42 mm (1½") ET
Pressure connection	33.3 mm (1") IT	33.3 mm (1") IT
Power cord	1.5 m	1.5 m
Product weight	9.8 kg	9.6 kg
Carry handle	•	•
Water filler screw	•	•
Prefilter with integrated non-return valve	-	-
Frost protection due to a water drain screw	•	•
High-quality mechanical seal	•	•
Suction hose included	-	-
Article number	41.814.60	41.814.50

GARDEN PUMPS



ROBUST



	GC-GP 6538 CLASSIC	GC-GP 6538 Set CLASSIC	GC-GP 6538 Set/I CLASSIC	GC-GP 6036 CLASSIC	GC-TP 4622 CLASSIC
Mains voltage	220 - 240 V ~ 50 Hz	220 - 240 V ~ 50 Hz	220 - 240 V ~ 50 Hz	230 V ~ 50 Hz	220 - 240 V ~ 50 Hz
Rated input	650 W	650 W	650 W	600 W	460 W
Max. delivery capacity / height	3800 l/h / 36 m	3800 l/h / 36 m	3800 l/h / 36 m	3600 l/h / 40 m	2250 l/h / 37 m
Max. suction height	8 m	8 m	8 m	8 m	-
Suction connection	33.3 mm (1") ET	33.3 mm (1") ET	33.3 mm (1") ET	33.3 mm (1") IT	33.3 mm (1") IT
Pressure connection	33.3 mm (1") ET	33.3 mm (1") ET	33.3 mm (1") IT	33.3 mm (1") IT	33.3 mm (1") IT
Power cord	1.4 m	1.4 m	1.4 m	1.5 m	1.5 m
Product weight	6.1 kg	6.1 kg	6.1 kg	9.5 kg	6.1 kg
Carry handle	•	•	•	•	-
Water filler screw	•	•	•	•	•
Frost protection due to a water drain screw	•	•	•	•	•
High-quality mechanical seal	•	•	•	-	-
Suction hose included	-	• (7 m)	• (4 m)	-	-
Article number	41.802.80	41.802.83	41.802.86	41.802.69	41.834.00



AUTOMATIC HOME AND GARDEN PUMPS 'PLUS'

Einhell Automatic Home and Garden Pumps 'Plus' have innovative features to make them even more user-friendly than previous automatic home and garden pumps.

Starting up and troubleshooting are even easier than ever before thanks to innovative status indicators such as suction, dirt and water filling indicators. For a long service life, low maintenance and exceptional protection, special safety mechanisms such as the flow sensor, dry running protection, scalding protection and frost protection are included. Like every Einhell pump, they have thermo protection to prevent any damage from overheating of the motor.

AUTOMATIC HOME AND GARDEN PUMPS 'PLUS'



	GE-AW 1246 N FS EXPERT	GE-AW 1042 FS EXPERT
Mains voltage / rated input	220 - 240 V ~ 50 Hz / 1200 W	220 - 240 V ~ 50 Hz / 1050 W
Max. delivery capacity / height / pressure	4600 l/h / 50 m / 5.0 bar	4200 l/h / 48 m / 4.8 bar
Max. suction height	8 m	8 m
Suction connection	42 mm (1¼") ET	42 mm (1¼") ET
Pressure connection	33.3 mm (1") IT	33.3 mm (1") IT
Additional pressure side connection	33.3 mm (1") IT	33.3 mm (1") IT
Power cord	1.5 m	1.5 m
Product weight	15.0 kg	15.0 kg
Automatic mode	•	•
Timer function	•	-
Water filler screw	•	•
Water filling / dirt / suction indicator	• / • / •	• / • / •
Integrated pre-filter with non-return valve	•	•
Carry handle	Comfort	Comfort
Frost protection due to a water drain screw	•	•
Thermo protection	•	•
Water flow recognition sensor / dry running protection / scalding protection	• / • / •	• / • / •
Incl. adapter 33.3 mm (1") ET	•	•
Article number	41.770.20	41.770.10



THE COMPLETE SUPPLY PACKAGE – FOR THE HOUSE AND THE GARDEN.

Einhell Automatic Home and Garden Pumps are perfect for house and garden: Whether for automatic domestic water supplies to provide service water for toilet flushing or washing machines or for automatic garden watering – this is no problem at all.

But what is the difference to a standard garden pump? An integrated flow switch automatically switches the pump on when a water demand is present and then off again, allowing this type of pump to be used fully automatically for domestic water supplies or for garden watering tasks, reducing the demand for valuable drinking water resources in the process.

AUTOMATIC HOME AND GARDEN PUMPS



	GC-AW 9036 CLASSIC	GC-AW 6333 CLASSIC
Mains voltage	230 V ~ 50 Hz	230 V ~ 50 Hz
Rated input	900 W	630 W
Max. delivery capacity / height / pressure	3600 l/h / 43 m / 4.3 bar	3300 l/h / 36 m / 3.6 bar
Max. suction height	7 m	8 m
Suction connection	42 mm (1½") ET	42 mm (1½") ET
Pressure connection	33.3 mm (1") IT	33.3 mm (1") IT
Power cord	1.5 m	1.5 m
Product weight	9.9 kg	7.8 kg
Carry handle	•	•
Water filler screw	•	•
Prefilter with integrated non-return valve	•	•
Frost protection due to a water drain screw	•	•
Indicator	LED	LED
Dry running protection	•	•
Automatic mode / timer function	• / –	• / –
ECO Power	–	–
Article number	41.767.20	41.767.30



WATER WORKS 'PLUS'

Starting up and troubleshooting are even easier than ever before thanks to innovative status indicators such as suction, dirt and water filling indicators. For a long service life, low maintenance and exceptional protection, some models have special safety mechanisms such as the flow sensor, dry running protection, scalding protection and frost protection. But every model has a thermo switch for protection against damage caused by overheating of the motor.

WATER WORKS 'PLUS'



	GE-WW 1246 N FS EXPERT	GE-WW 1145 ECO EXPERT	GC-WW 1045 N CLASSIC	GC-WW 8042 ECO CLASSIC
Mains voltage / rated input	220 - 240 V - 50 Hz / 1200 W	220 - 240 V - 50 Hz / 1100 W	220 - 240 V - 50 Hz / 1050 W	220 - 240 V - 50 Hz / 800 W
Max. delivery capacity / height	4600 l/h / 50 m	4500 l/h / 48 m	4500 l/h / 48 m	4200 l/h / 43 m
Max. suction height	8 m	8 m	8 m	8 m
Suction connection / Pressure connection	42 mm (1¼") ET / 33.3 mm (1") IT	42 mm (1¼") ET / 33.3 mm (1") IT	42 mm (1¼") ET / 33.3 mm (1") IT	42 mm (1¼") ET / 33.3 mm (1") IT
Additional pressure side connection	33.3 mm (1") IT	33.3 mm (1") IT	-	-
Tank volume	20 l	20 l	20 l	20 l
Max. activation / cut off pressure	1.5 bar / 3 bar	1.5 bar / 3 bar	1.5 bar / 3 bar	1.5 bar / 3 bar
Product weight	19.5 kg	19.5 kg	17.3 kg	13.3 kg
Water filler screw	•	•	•	•
Water filling / dirt / suction indicators	• / • / •	• / • / •	• / - / -	• / - / -
Integrated pre-filter with non-return valve	•	•	-	-
Carry handle	Comfort	Comfort	Comfort	Foldable
Frost protection due to a water drain screw	•	•	•	•
Thermo protection	•	•	•	•
Water flow recognition sensor / dry running protection / scalding protection	• / • / •	- / - / -	- / - / -	- / - / -
Incl. adapter 33.3 mm (1") ET	•	•	•	•
Article number	41.735.30	41.735.40	41.735.20	41.735.10

DOMESTIC WATER SUPPLIES **MADE EASY.**

Einhell Domestic Water Works are not only quiet and environmentally friendly, but they also represent a cost-effective alternative to domestic water supplies with drinking water. They enable clean water to be delivered from reservoirs, wells and shafts for use as service water in irrigation systems, washing equipment, toilet flushing systems and much more besides. The pressure vessel offers a capacity of 20 litres, so the pump does not need to start up every time water is drawn off.

An integrated pressure switch will activate the pump when the pressure drops and deactivate it again when the pressure returns to maximum. On the integrated pressure gage you can read off the pressure at a glance.

WATER WORKS



	GC-WW 1250 NN CLASSIC
Mains voltage / rated input	220 - 240 V ~ 50 Hz / 1200 W
Max. delivery capacity / height	5000 l/h / 50 m
Max. suction height	8 m
Max. activation / cut off pressure	1.5 bar / 3 bar
Tank volume	20 l
Suction connection	42 mm (1 1/4") ET
Pressure connection	33.3 mm (1") IT
Product weight	14.7 kg
Overload protection	•
Water filler screw	•
Water drain screw	•
High-quality mechanical seal	•
INOX stainless steel pressure tank	•
Prefilter with integrated non-return valve	-
Pressure gauge	•
Suction hose included	-
Article number	41.734.90

WATER WORKS



	GC-WW 1046 N CLASSIC	GC-WW 6538 CLASSIC	GC-WW 6538 Set CLASSIC	GC-WW 6036 CLASSIC
Mains voltage / rated input	220 - 240 V ~ 50 Hz / 1050 W	220 - 240 V ~ 50 Hz / 650 W	220 - 240 V ~ 50 Hz / 650 W	230 V ~ 50 Hz / 600 W
Max. delivery capacity / height	4600 l/h / 48 m	3800 l/h / 36 m	3800 l/h / 36 m	3600 l/h / 40 m
Max. suction height	8 m	8 m	8 m	8 m
Max. activation / cut off pressure	1.5 bar / 3 bar	1.5 bar / 3 bar	1.5 bar / 3 bar	1.5 bar / 3 bar
Tank volume	20 l	20 l	20 l	20 l
Suction connection	42 mm (1¼") ET	33.3 mm (1") ET	33.3 mm (1") ET	33.3 mm (1") IT
Pressure connection	33.3 mm (1") IT	33.3 mm (1") ET	33.3 mm (1") ET	33.3 mm (1") IT
Product weight	14.4 kg	10.5 kg	10.5 kg	14.3 kg
Overload protection	•	•	•	•
Water filler screw	•	•	•	•
Water drain screw	•	•	•	-
High-quality mechanical seal	•	•	•	-
INOX stainless steel pressure tank	-	-	-	-
Prefilter with integrated non-return valve	-	-	-	-
Pressure gauge	•	•	•	•
Suction hose included	-	-	• (7 m)	-
Article number	41.734.80	41.731.90	41.731.93	41.731.18

FULL POWER – WITHOUT ANY ELECTRICITY AT ALL.

With Einhell Petrol Water Pumps, you are always independent of a mains power supply – whether on a camping trip or working in your allotment. The petrol-powered water pumps are suitable not only for harsh, high-performance applications for mains supply-independent water supply tasks, but also for numerous permanent drainage tasks. Thanks to the low-consumption pump technology, these pumps are ideally suited to numerous permanent drainage and watering tasks.

PETROL WATER PUMPS



	GE-PW 46 EXPERT	GC-PW 16 CLASSIC
Motor	Four-stroke	Four-stroke
Power rating	4.6 / 6.3	1.6 / 2.2
Max. delivery capacity / height	23000 l/h / 26 m	14000 l/h / 28 m
Max. suction height	6.5 m	7.0 m
Max. speed	3600 min ⁻¹	3600 min ⁻¹
Suction connection	59.6 mm (2") ET	47.8 mm (1½") ET
Pressure connection	59.6 mm (2") ET	47.8 mm (1½") ET
Fuel tank capacity	3.6 l	1.8 l
Product weight	23.0 kg	11.2 kg
Non-return valve	•	•
Sturdy steel tube frame	•	–
Water filler port	•	•
Water drain screw	•	•
Oil filling screw	•	•
Low oil stop	•	•
Incl. hose adapter	2x 50.8 mm (2")	2x 38.1 mm (1.5")
Incl. intake cage	• (2")	• (1.5")
Incl. reducer section	2x 47.8 mm (1.5") ET, 2x 33.3 mm (1") ET	–
Article number	41.713.72	41.905.30



SURFACE PUMPS – ACCESSORIES



	Suction Hose	Suction Hose	Suction Hose	Suction Hose
Length	4 m	4 m	7 m	7 m
Connectors material	Brass	Plastic	Brass	Plastic
Connectors	42 mm (1¼") IT	42 mm (1¼") IT	42 mm (1¼") IT	42 mm (1¼") IT
Hose diameter	25 mm (1")	25 mm (1")	25 mm (1")	25 mm (1")
Threaded nipple	33.3 mm (1") ET	33.3 mm (1") ET	33.3 mm (1") ET	33.3 mm (1") ET
Adapter	-	33.3 mm (1") IT	-	33.3 mm (1") IT
Article number	41.736.30	41.736.35	41.736.40	41.736.45

SURFACE PUMPS – ACCESSORIES



	Coarse Filter	Coarse Filter
Height of filter insert	12 cm	25 cm
Brass internal thread	33.3 mm (1") IT	33.3 mm (1") IT
Max. operation pressure	5.5 bar	5.5 bar
Max. delivery quantity	4300 l/h	4000 l/h
Cartridge included	•	•
Connector	33.3 mm (1") ET / 42 mm (1 1/4") IT	33.3 mm (1") ET / 42 mm (1 1/4") IT
Double nipple	33.3 mm (1") ET	33.3 mm (1") ET
Cartridge included	•	•
Article number	41.738.01	41.738.51

SURFACE PUMPS – ACCESSORIES



	Electronic Flow Switch
Brass internal thread	33.3 mm (1") IT
Power cord	1.45 m
Non-return valve	•
Connection-adaptor	33.3 mm (1") ET / 33.3 mm (1") ET
Dry running protection	•
Article number	41.742.21

SURFACE PUMPS ACCESSORIES

MISCELLANEOUS

HOSES



Electronic Flow Switch	41.742.21		AQUINNA 36/30	GE-GP 1246 N FS	GE-GP 1145 ECO	GC-GP 1250 N	GC-GP 1045	GC-GP 8042 ECO	GC-GP 6040 ECO	GC-GP 1250 N	GC-GP 1046 N	GC-GP 6538	GC-GP 6036	GC-TP 4622
Coarse Filter 12 cm with cartridge	41.738.01													
Coarse Filter 25 cm with cartridge	41.738.51													
Suction Hose 4 m with brass connections	41.736.30													
Suction Hose 4 m with plastic connections	41.736.35													
Suction Hose 7 m with brass connections	41.736.40													
Suction Hose 7 m with plastic connections	41.736.45													

GE-AW 1246 N FS												
GE-AW 1042 FS	•											
GC-AW 9036	•	•										
GC-AW 6333	•	•	•									
GE-WWW 1246 N FS	•	•	•									
GE-WWW 1145 ECO	•	•	•									
GC-WWW 1045 N		•										
GC-WWW 8042 ECO		•										
GC-WWW 1250 NN		•										
GC-WWW 1046 N		•										
GC-WWW 6538	•											
GC-WWW 6036	•	•	•									





**PUMPING MADE EASY.
WATER TECHNOLOGY
FOR HOUSE AND GARDEN.**

Einhell Germany AG

Wiesenweg 22
94405 Landau/Isar
Germany

info@einhell.de
www.einhell.de

Einhell Service

Eschenstr. 6
94405 Landau/Isar
Germany

Tel. +49 (0) 9951 959 2000

Service-DE@einhell.com
www.einhell-service.com



einhell.de
>>>